



SANY

Quality Changes the World



SANY TELESCOPIC CRAWLER CRANE SCC 550TB

TELESCOPIC CRAWLER CRANE

CONTENT

P03

SCC550TB Crawler Crane

Outline Dimensions
Technical Features
Performance Parameters Table
Transport program
Self-disassembly Diagram
Transportation Dimensions

P10

Specifications

Superstructure
Undercarriage
Operation Devices
Safety Devices

P17

Operating Condition Combination

Operating Range Diagram of SCC550TB
Boom Load Chart
Jib Load Chart

SCC550TB

03	Outline Dimensions
04	Technical Features
05	Performance Parameters Table
06	Transport Program
07	Self-disassembly Diagram
08	Transportation Dimensions

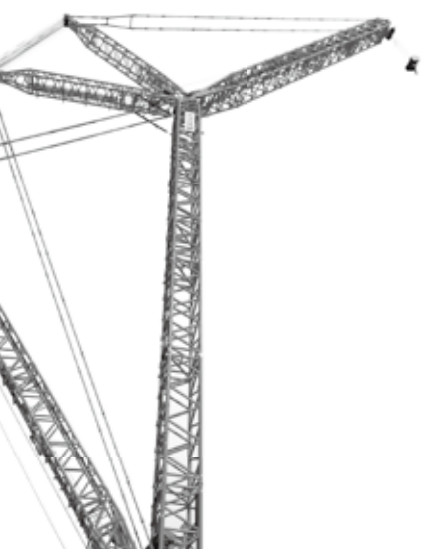

OUTLINE DIMENSIONS

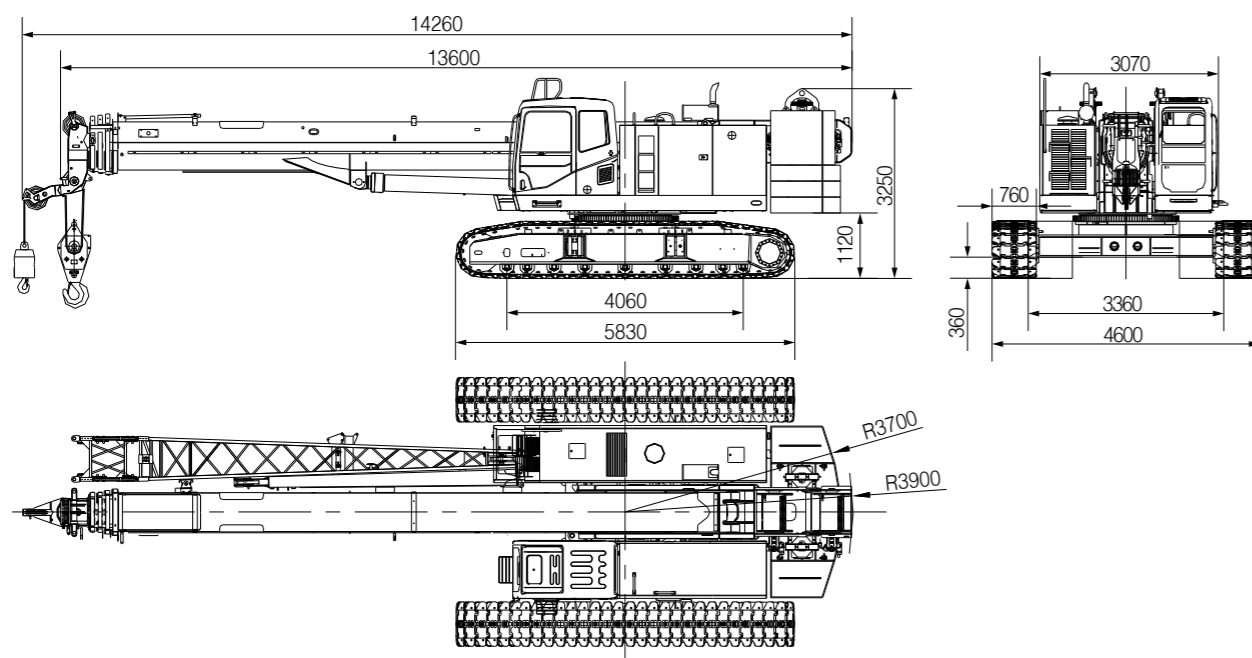

TECHNICAL FEATURES

1. Highly Secured Control System:

There are two operation modes, working and assembly for your convenience. It features with electronic level gauge, machine-leaving stop action, and emergency electrical control, with complete set of safety and monitoring device. Load moment limiter is free of calibration, providing higher safety of the equipment, and less auxiliary operating time to improve the safety of the equipment;

2. Excellent Operating Performance:

Maximum load regulation and electronic proportion controls ensure smooth micro-movement and stable operation. A real-time queried electronic load chart is provided, more conveniently and quickly;

3. Reliable Function Assurance:

The safety margin in structural design is sufficient; the hydraulic system is equipped with advanced distribution system which is independent of load and the key parts such as pumps, valves, motors, and reducers are adopted to ensure system stability and reliability. The control system is fully capable to function stably in extreme weather, such as high-and-cold, high-temperature, and high plateau weather; sensor has a protection against lightning strike; the entire machine adopts the closed wiring way, with waterproof / dust-proof protective grade up to IP65; the machine passed the verification test of the strength that is higher above two times of that in industry having high reliability;

4. Convenient Maintenance Access:

It takes no more than 10min/person to adjust, no more than 30 min/person for daily maintenance and no more than 2h/person to repair the machine.

5. Powerful Lifting Capacity:

Wide-track chassis is design to ensure excellent overall and operating stability within 360° slewing range, the max. lifting capacity of boom is 37t×4.5m=166t·m., the length of fully extended boom is 42m and the rated single rope pull of main and auxiliary winch is 5.1t.

6. High-efficient operating speed:

Outmost layer line speed of main and auxiliary lifting winches is 120m/min ;

7. Optimized Transportation Programs:

With telescopic crawler, the maximum transportation width of whole machine is 3.36m, overall weight is 59.5t and self-disassembly/assembly could be achieved and the max. single transport weight is 37t (excluding jib and auxiliary winch).

PERFORMANCE PARAMETERS TABLE

Performance Parameters of SCC550TB Crawler Crane			
Item		Unit	Parameter
Boom Operating Condition	Max. Rated Lifting Capacity	t	55
	Boom Length	m	11.3~42
	Boom Luffing Angle	°	-2° ~80°
	Max. Rated Lifting Torque	t·m	187
Jib Operation	Fully extended boom + jib	m	42+13
	Jib offset	°	0°、15°、30°
Working Speed	Rope Speed of Main and Auxiliary Winches (outermost layer)	m/min	0~120
	Full lifting/descending time of boom	s	60/60
	Full extension/retraction time of boom	s	100/90
	Slewing speed	rpm	0~2.1
	Traveling speed	km/h	0~2.1
Engine	Rated power	kw	154
Transportation Parameter	Overall weight	t	59.5
	Max. single transport weight	t	37 (without jib and auxiliary winch)
	Dimensions (L×W×H)	mm	14000×3360×3250
Other Parameter	Average ground pressure	MPa	0.09
	Min slewing radius	mm	3900 (3700 without auxiliary winch)

TRANSPORT PROGRAM

Overall transport with all devices:
Weight: 59t , Dimension:14000×3360×3250mm

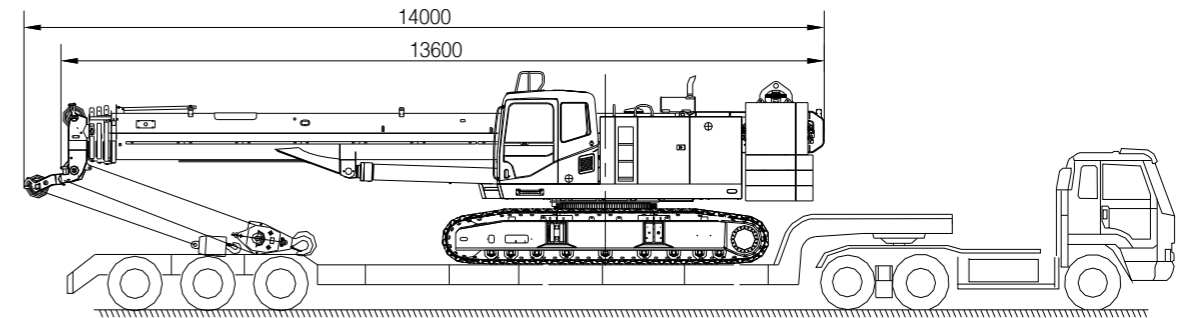

SELF-DISASSEMBLY DIAGRAM

If the counterweight must be disassembly for transportation, the rear counterweight could be disassembly by itself without other crane.

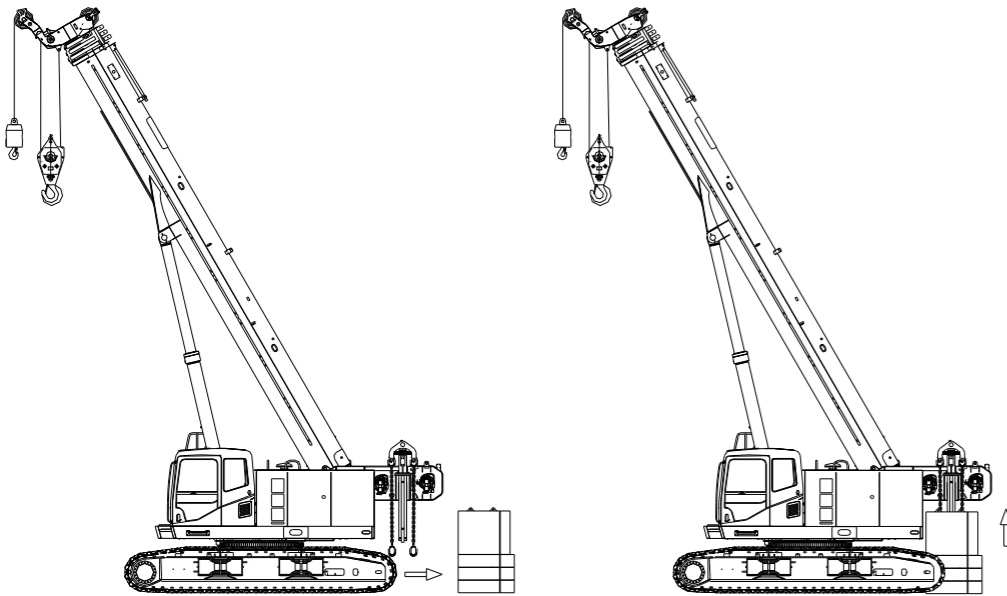

TRANSPORTATION DIMENSIONS

Complete Machine	×1
Length(L)	14.0m
Width(B)	3.36m
Height(H)	3.25m
Weight	59.5t
Body(include jib)	×1
Length(L)	14.0m
Width(B)	3.36m
Height(H)	3.25m
Weight	39.5t
Counterweight tray	×1
Length(L)	2.94m
Width(B)	1.18m
Height(H)	1.04m
Weight	4.8t
Rear Counterweight	×2
Length(L)	2.94m
Width(B)	1.18m
Height(H)	0.40m
Weight	4.8t
Rear Counterweight	×2
Length(L)	1.10m
Width(B)	0.72m
Height(H)	0.40m
Weight	4.3t
5t Hook	×1
Length(L)	0.67m
Width(B)	0.25m
Height(H)	0.25m
Weight	0.1t
60t Hook	×1
Length(L)	1.65m
Width(B)	0.69m
Height(H)	0.39m
Weight	0.6t

Notes:

1. The transportation dimensions are not drawn to proportion. The dimensions in the sketch are design value excluding packages.
2. The weight is design value and there may be tiny difference due to the manufacturing calibration and the total weight of counterweight is 20t.
3. After product upgrading, the actual weight is subjected to the latest products.

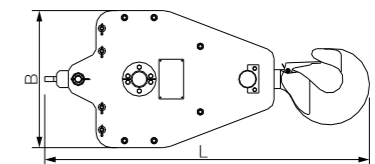
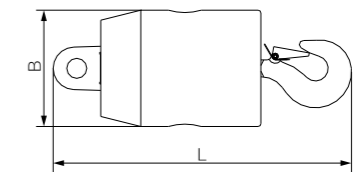
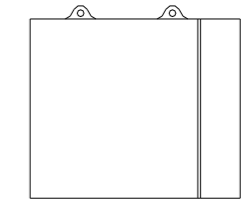
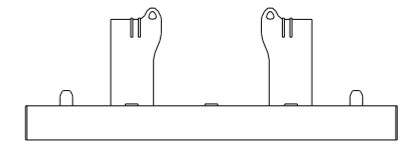
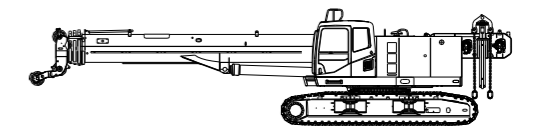
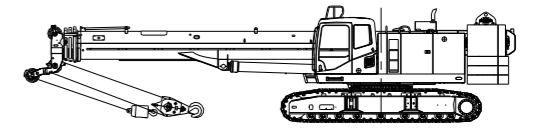

SCC550TB

Superstructure	10
Undercarriage	12
Operation Devices	13
Safety Devices	14

SPECIFICATIONS / SUPERSTRUCTURE

1) Engine

- QSB5.9-C210 154kW, 6-cylinder, turbine charger & air-air intercooler
- Displacement: 5.9L
- Rated Power: 154kW/2200rpm
- Max. torque: 870Nm/1400rpm
- Emission Standard: GB III
- Fuel Tank Capacity: 400L.

2) Electrical Control System

- The CAN bus technology is applied for data communication between integrated moment intelligent control system and data recorder, and for saving the relevant data.
- Display can show engine speed, fuel level, oil pressure, servo pressure, wind speed, engine working time, weight of load lifted by crane, working radius, and lifting boom angle; electronic load chart has a real-time inquiry function, providing the convenient and quick inquiry; the complete fault self-diagnosis and inquiry system is provided, thus reducing the equipment fault handling time.
- Sensor has a protection against the lightning strike, providing higher reliability.
- The entire machine adopts the closed wiring way, with waterproof / dust-proof protective grade up to IP65 and with longer life applied.

3) Hydraulic System

- Electronic proportion control hydraulic system is adopted, including main pump, main valve, joystick and motor reducer, which are efficient, reliable, stable and energy-saving.
- Advanced rotation and micro-movement performance and limit load regulation ensure smooth and stable operation.

4) Main and Auxiliary Hoisting Mechanisms

- The winch drum is directly driven by winch motor through reducer, and can rotate into two directions through the manipulation of luffing handle to carry out lifting and lowering actions of the hook.
- Motor reducer of well-known brand is adopted for higher reliability and durability.
- The drum design ensures the multi-layer winding is always in order.
- Steel wire of well-known brand is adopted for higher reliability and durability.

NO.1 Main & Auxiliary Winch

Wire Rope speed(outermost layer)	0~120m/min
Wire rope diameter	Φ18mm
Wire rope length of main winch	220m
Wire rope length of auxiliary winch	130m
Rated single line pull	5.1t

SUPERSTRUCTURE

5) Luffing System

- Hydraulic cylinder with safe balance valves. Luffing angle is $-2^{\circ} \sim 80^{\circ}$. Dead-weight luffing provides more stable luffing operation at low energy loss.

6) Slewing System

- Slewing system is equipped with integrated slewing cushion valve and the function of free slewing. It is stable to start and control the slewing with excellent micro-movement
- The speed is controlled by electronic proportion with stable and reliable performance. The unique design for slewing cushion ensures more stable braking.
- External toothing slewing driving ensures 360° rotation with max. speed of 2.1r/min
- Slewing lock: Pull up the locking pin after the completion of operation or during transportation can ensure the superstructure to be locked, which is convenient and reliable.
- Slewing support: Single-row ball type slewing support.

7) Counterweight

- Counterweight blocks could be combined and disassembly by the crane itself which is convenient for transportation.

8) Cab

- SANY's newly designed cab features with artistic styling and interior decoration, with large glass windows. There are short and long distance beam headlight, and rear-view mirror for more open vision. It is equipped with cooling & heating air conditioning and radio. The seat, joystick and all control buttons are all ergonomically designed, which provides the operator with a more comfortable working environment.
- Armrest box: Joystick, electric switch, emergency stop button and ignition lock are installed on left and right armrest box and auxiliary controlling box. The armrest box is adjustable with the seat.
- Seat: Suspension, multimode, and multistage adjustable seat is adopted, with unloading switch applied.
- Air conditioning provides heating and cooling air with optimized air duct and air outlet.

UNDERCARRIAGE

1) Traveling Drive

Each track frames has an independent traveling drive. The traveling motor drives the machine to achieve independent traveling and turning through drive wheel and reducer. the max. gradeability is 45%.

2) Traveling Brake

The concealed, wet and spring loaded normally closed brake is adopted, with spring force for braking and oil pressure for release.

3) Telescopic Crawler

Crawler frame can be expanded and retracted through cylinder.

4) Crawler Tensioning

Crawler tension can be adjusted by using hydraulic jack to push guide wheel to adjust clearance between shims.

5) Track Shoes

High strength alloy steel with higher durability.

6) Travelling Speed

0~2.1km/h (Empty loaded on hard and level ground)
There are two switches: Fast / Slow.

OPERATION DEVICES

1) Boom

- Five-section boom is applied with basic boom length of 11.3m, full-extended boom length of 42m, It is made of fine grain high-strength steel with U-shaped cross section which makes the stress distributed properly. The telescopic operation is controlled by dual-cylinder rope system which is more efficient and safe.

2) Fixed Jib

- Two-section jib of 7.4m and 5.6m. the jib offset is 0°, 15° and 30° which is convenient to meet the operation condition and improve the working efficiency.

3) Boom Tip Pulley

It is welding structure and connected with boom by pins for auxiliary hook operation.

4) Lifting Hook

S/N	Lifting Capacity (t)	Pulley	Weight(t)	Quantity
1	60	6	0.61	1
2	5	1	0.09	1

Notes:
Above devices are complete configuration and the actual configuration is subject to the P/O contract.

SAFETY DEVICES

1) Integrated moment intelligent control System

- Standard configured SANY load moment limiter is free of calibration, ensuring the high safety and efficiency of the equipment construction.
- It is equipped with load moment calculation system based on the lifting mechanical model. The precise of rated lifting capacity could achieve 0-10% by no-load calibration. The system will alarm if overload which ensure the safe of the operation.
- The load moment control system will monitor the real-time load, working radius and boom angle and compare it with rated load and the radius and boom angle automatically. It will judge and stop the improper operation automatically under normal operation and it could take record of the overload information like black box.
- Main compositions: Display, controller, angle sensing, and load sensor.

2) Assemble/Operation Mode Change Switch

In assembly mode, over hoisting limiter, and load moment indicator will be bypassed for the assembly of the crane. In operation mode, all safety limit devices will work.

3) Emergency Stop

In case of emergency, the operator can immediately shut down the entire machine by pressing the emergency stop button.

4) Main and Auxiliary Hoisting Limiter

Composed of limit switch and hammer etc. on boom tip to prevent over hoisting of hook block. When the lifting hook is raised to a certain height, the limit switch will be activated. The buzzer on the control panel will alarm and the failure indicator will flash. The lifting operation of hook block will be automatically cut off.

5) Lowering Limiter of Main and Auxiliary Winch

Composed of movement trigger device and proximity switches to prevent wire rope from being over-released. When the wire rope is released near the last three loops, limit switch will work. The system will alarm through buzzer, sending alarm information to the display and automatically stop the lowering of winches.

6) Function Lock

If the function locking handle is not at proper position, all control handles will not function. It can prevent misuse and operational accident due to body impact when getting on or off the cab.

7) Slewing Lock Devices

There are two ways to lock the slewing operation. Electronic lock: it must be unlocked in the system before operation to prevent the wrong operation of joystick. Mechanical lock: it is locked by pins. The crane can be locked at the front and rear side.

8) Hook Latch

There are baffle on the hook to prevent the wire rope fall off.

9) Remote Monitoring System

Remote monitoring system is optional for GPS positioning, GPRS data transfer, machine use inquiries, running data monitoring, analysis and remote fault diagnosis.

SAFETY DEVICES

10) Three-color Load Alarm Light

Red, Yellow and Green lights indicate loading situations in Real-Time. If the actual load is less than 90% of the rated load, the Green light will turn on. If the actual load is more than 90%, but less than 100% of the rated load, the Yellow light will turn on with intermittent sound alarm. If the actual load is 100% of the rated load, the Red light will turn on with continuous sound alarm. If the actual load is 100% of the rated load, then the system will immediately cease the operation of the crane.

11) Audio and Visual Alarm

When the integrated moment intelligent control system is powered, audio and visual alarm will flash.

12) Slewing Alarm

When the machine is traveling or slewing, the slewing lamp will flash.

13) Unmanned Protection

If there was no operator sitting on the chair, all operations would not work to prevent improper operations.

14) Illumination Light

The short-beam lamp at the front of cab, front angle adjustable far-beam lamp, cab lamp and other lighting device at night are equipped to improve the visibility of construction.

15) Rearview Mirror

It will be mounted at front of cab and at right platform handrail and winch.

16) Gradiometer

Electronic gradiometer is equipped and the screen could display the angle of inclination of the crane

17) Monitoring System

Two monitors and light are mounted at the tail of slewing platform which let the operator to know the condition of crane rear part and winches through the display screen. (these are optional configuration)

SCC550TB

17 Operating Range Diagram of SCC550TB

18 Boom Load Chart

19 Jib Load Chart



OPERATING RANGE DIAGRAM OF SCC550TB

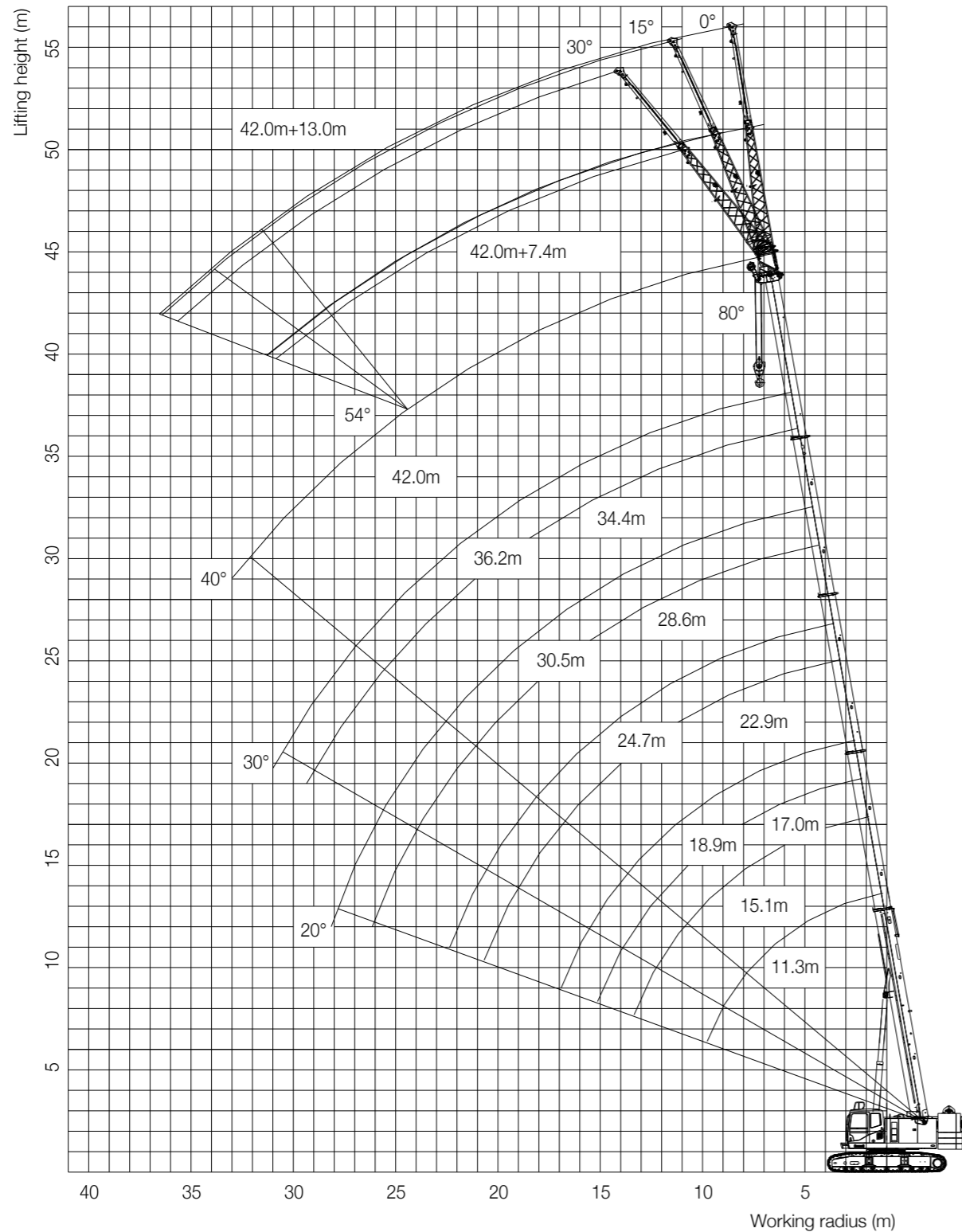

BOOM LOAD CHART

SCC550TB Boom Load Chart unit: (t)

Radius (m)	11.3	15.1	17	18.9	20.8	22.9	24.7	26.6	28.6	30.5	32.4	34.4	36.2	38.2	42	Radius (m)
3.0	55.0															3.0
3.5	50.0	35.0	21.0	33.0												3.5
4.0	45.0	34.0	20.0	33.0	22.5											4.0
4.5	41.0	32.0	18.5	31.5	21.0	15.5	24.5									4.5
5.0	37.5	30.0	17.0	29.5	20.0	15.0	22.5	16.5								5.0
5.5	32.5	28.0	15.5	27.5	19.0	14.0	21.0	15.5								5.5
6.0	28.5	26.0	14.5	25.1	17.5	13.5	20.0	15.0	12.0	16.5						6.0
6.5	25.0	23.0	13.5	22.5	16.5	12.5	19.5	14.5	11.5	15.5	12.5					6.5
7.0	22.0	21.6	13.0	20.3	16.0	12.0	18.5	13.6	11.0	15.0	12.0	9.0	13.0			7.0
7.5	19.6	19.2	12.5	18.4	15.0	11.0	17.5	12.8	10.5	14.5	11.5	9.0	12.5			7.5
8.0	17.7	17.2	12.0	16.9	14.5	10.5	16.5	12.2	10.0	14.0	11.0	8.5	12.0	9.0		8.0
9.0	14.5	14.1	11.5	13.9	11.5	10.0	14.3	11.0	9.0	12.5	10.0	8.0	11.0	8.5	8.6	9.0
10.0		11.8	10.0	11.6	10.5	9.2	12.3	10.0	8.2	12.0	9.2	7.5	10.0	8.0	8.6	10.0
11.0		10.0	9.0	9.8	9.5	8.8	10.7	9.6	7.6	10.7	8.5	7.0	9.3	7.5	8.0	11.0
12.0		8.5	8.2	8.3	8.5	8.2	9.4	9.2	7.2	9.5	8.0	6.6	8.8	7.0	7.5	12.0
14.0			7.5	6.0	7.3	7.6	7.0	7.8	6.7	7.5	7.5	6.1	7.6	6.5	6.5	14.0
16.0				4.3	5.7	6.6	5.3	6.2	6.2	5.9	6.5	5.6	6.1	6.0	5.8	16.0
18.0						5.4	4.0	5.0	5.7	4.6	5.3	5.1	5.0	5.5	5.1	18.0
20.0							3.0	4.0	4.7	3.6	4.3	4.6	4.0	4.6	4.2	20.0
22.0								3.2	3.9	2.8	3.5	4.1	3.2	3.8	3.5	22.0
24.0									3.3	2.2	2.9	3.5	2.5	3.1	2.8	24.0
26.0										1.6	2.3	2.9	2.0	2.6	2.3	26.0
28.0											1.8	2.4	1.5	2.1	1.8	28.0
30.0												2.0	1.1	1.7	1.4	30.0
32.0														1.3	1.1	32.0
Part of line	12	10	6	8	6	4	6	4	4	4	4	3	4	3	3	Part of line
Min elevation													20°	20°	20°	Min elevation
Telescopic Condition (%)																
Telescopic Mode	I II	I	II	I	II	II	I	III	II	I	III	II	I	III	II	Telescopic Mode
2rd Section	0	50	0	100	50	0	100	50	0	100	50	0	100	50	100	2rd Section
3th Section	0	0	25	0	25	50	25	50	75	50	75	100	75	100	100	3th Section
4th Section	0	0	25	0	25	50	25	50	75	50	75	100	75	100	100	4th Section
5th Section	0	0	25	0	25	50	25	50	75	50	75	100	75	100	100	5th Section

JIB LOAD CHART

Jib Load Chart of SCC550TB						
Boom Elevation	Boom + Jib (m)					
	42+7.4m			42+13m		
	0°	15°	30°	0°	15°	30°
78°	3.5	2.4	2	2.4	1.5	1
77°	3.2	2.3	1.9	2.4	1.4	1
75°	3	2.2	1.8	2.3	1.3	1
73°	2.7	2	1.7	2	1.2	0.9
71°	2.5	1.8	1.6	1.8	1.1	0.9
68°	2.2	1.7	1.4	1.5	1	0.8
66°	2	1.5	1.3	1.3	1	0.8
63°	1.8	1.4	1.1	1.1	0.9	0.7
61°	1.5	1.2	1	1	0.8	0.7
58°	1.1	1	0.8	0.7	0.6	0.6
56°	0.7	0.7	0.6	0.5		
Min Elevation	54°					

Notes:

1. When the crane is hoisting, the crawler frame must be in the state of extension
2. The rated load indicated in the table is the weight hoisted slowly and steadily on hard soil ground and the gradient is not over 1° when the crane is not travelling.
3. The rated load indicated in the table is the calculated value by taking 75% of the tipover load when the wind speed is below 9.8m/s.
4. All values in the load chart are applicable for 360° rotation.
5. The rated lifting capacity is not over 0.4t when the boom tip pulley is applied. If the jib is mounted, the rated lifting capacity of boom must be reduced by 2.3t.
6. The rated load value in the table includes the weight of hook, wire rope and other lifting tools(main hook is 0.61t and auxiliary hook is 0.09t). The actual hoisting capacity is the rated value minus the weight of all lifting tools



Quality Changes the World

SANY HEAVY INDUSTRY CO., LTD.

Address: SANY Industrial Park, Economic and Technological
Development Zone, Changsha, Hunan, China

Service Hotline: +0086-4006-098-318

E-mail: crd@sany.com.cn

For more information, please visit: www.sanygroup.com

